

Refrigeration Equipment Slide Top Mug/Glass Froster Stainless Steel 24" Long

ITEM # _____

MODEL # _____

NAME # _____

SIS # _____

AIA # _____



738364 (KCHGF24SS)

Slide Top Mug/Glass Froster
Stainless Steel 24" Long

Short Form Specification

Item No. _____

24" wide glass/mug/plate froster with slide top. Exterior back and side panels in 430 stainless steel, exterior bottom panel in galvanized steel, top panel in 304 stainless steel; interior back and side panels in painted aluminum, interior bottom panel and worktop in 304 stainless steel. Fin & tube condenser to improve the performances in high temperature environments. Automatic Defrost Cooling System and electronic temperature control. Vinyl-coated steel adjustable dividers and locking lids.

R600a gas in refrigeration circuit.
ETL Safety and Sanitation certified.
3/5 Years warranty

Main Features

- ADA Height Compliant
- External digital temperature display.
- Fin & Tube Condenser improves performance in high temperature environments.
- Automatic Defrost Cooling System provides worry-free performance.
- Electronic Temperature Control, quick and simple to set, with control display for easy monitoring.
- Cabinet completely insulated with high density polyurethane for low environmental impact.
- Vinyl-coated steel adjustable dividers to customize storage effortlessly
- Heavy duty vinyl coated steel floor protector shelves
- Cabinet capable of accepting 40 standard 16-ounce pint glasses
- Cabinet capable of accepting 24 standard 16-ounce glass mugs

Construction

- Stainless steel body.
- Painted white aluminum interior, durable and easy to clean for daily commercial use
- Pre-wired heavy duty power cord.
- Electronic control to select temperatures.
- Smooth rolling wheels, for effortless mobility
- Stainless steel worktop, durable functionality

Sustainability

- CFC and HCFC free (ecological refrigerant type: R600a).
- High efficiency components to minimize the energy consumption still guaranteeing the highest performances.
- 60 mm insulation for energy saving.

APPROVAL: _____

Front

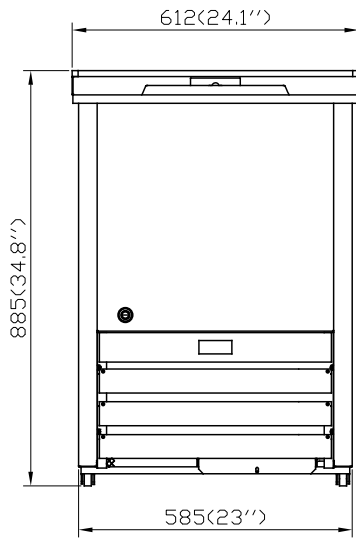

Side

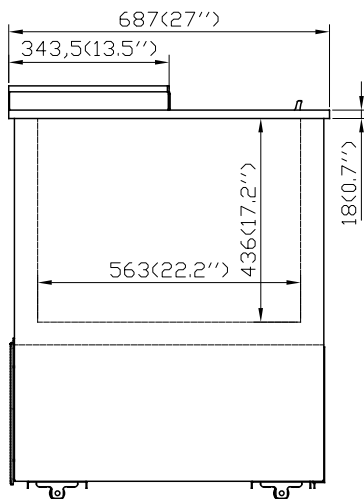

EI = Electrical connection

Top

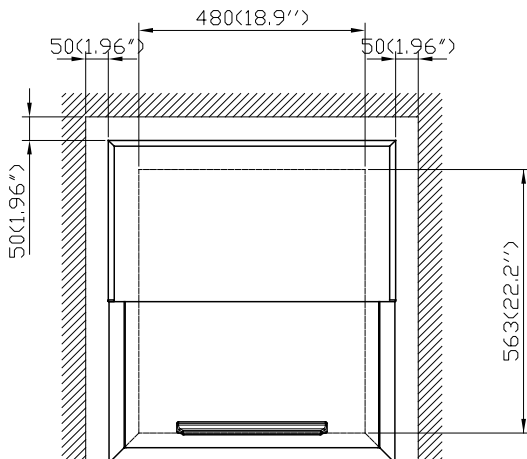

Electric

Supply voltage:	115 V/1 ph/60 Hz
Plug type:	NEMA 5-15

Capacity:

Gross capacity:	3 cu.feet
-----------------	-----------

Key Information:

Warranty:	3 / 5 years
Door hinges:	
External dimensions, Width:	24 1/16" (612 mm)
External dimensions, Depth:	27 1/16" (687 mm)
External dimensions, Height:	34 13/16" (885 mm)
Number and type of doors:	1 Full
Internal Dimensions (depth):	14 3/4" / (375 mm)
Internal Dimensions (height):	13 3/4" / (350 mm)
Internal Dimensions (width):	16 7/8" / (428 mm)
Shipping height:	39 3/8" (1000 mm)
Shipping weight:	148 lbs (67 kg)
Shipping volume:	16.98 ft ³ (0.48 m ³)
Type of external material:	Stainless Steel
Type of internal material:	White Prepainted Aluminium
Approvals	ETL C&US;ETL SANITATION

Refrigeration Data

Condenser type:	Fin & tube
Operating temperature min.:	-5.01 °F
Compressor power:	1/5 hp
Operating temperature max.:	-2 °F
Defrost type:	Automatic

Sustainability

Current consumption:	1.5 Amps
Refrigerant type:	R600a
GWP Index:	3
Refrigerant weight:	100 g



Refrigeration Equipment
Slide Top Mug/Glass Froster Stainless Steel 24" Long

The company reserves the right to make modifications to the products without prior notice. All information correct at time of printing.